

M480-2EX
74x58 Digital Mixing System

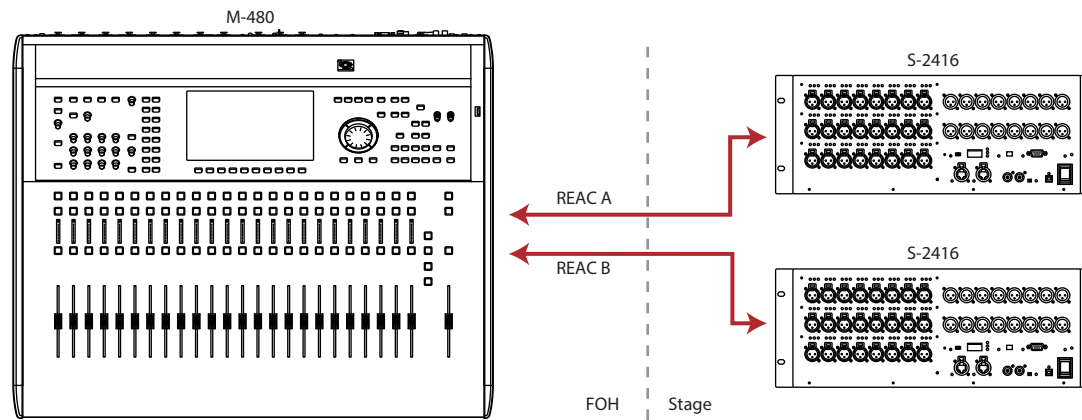

M480-2EX
74x58 Digital Mixing System

This system is the ideal solution for a large band setup with up to 74 inputs and 58 outputs. It allows for 48 input channels (+16 digital) onstage with 32 outputs (+16 digital) all accessible from the stage side. The system consists of the M-480 48-Channel V-Mixer and two S-2416 Digital Snake heads.

Package includes:

- M-480 V-Mixer
- 2 x S-2416 Digital Snake

Main Features:

- 60 channels of digital mixing (48Ch plus 6 stereo returns)
- 74 x 58 digital audio I/O and transport
- Remotely placed and controlled I/O across two 24 x 16 snake heads
- Full control of all system components from V-Mixer interface as well as PC/Mac

System: M480-2EX

Roland
Professional A/V

5100 S. Eastern Avenue
Los Angeles, CA 90040-2938
Phone: (800) 380-2580
www.rolandsystemsgroup.com