

M5000-22416PMR

64x48 Digital Mixing with Personal Mixing and Multi-Channel Playback/Virtual Rehearsal/Recording

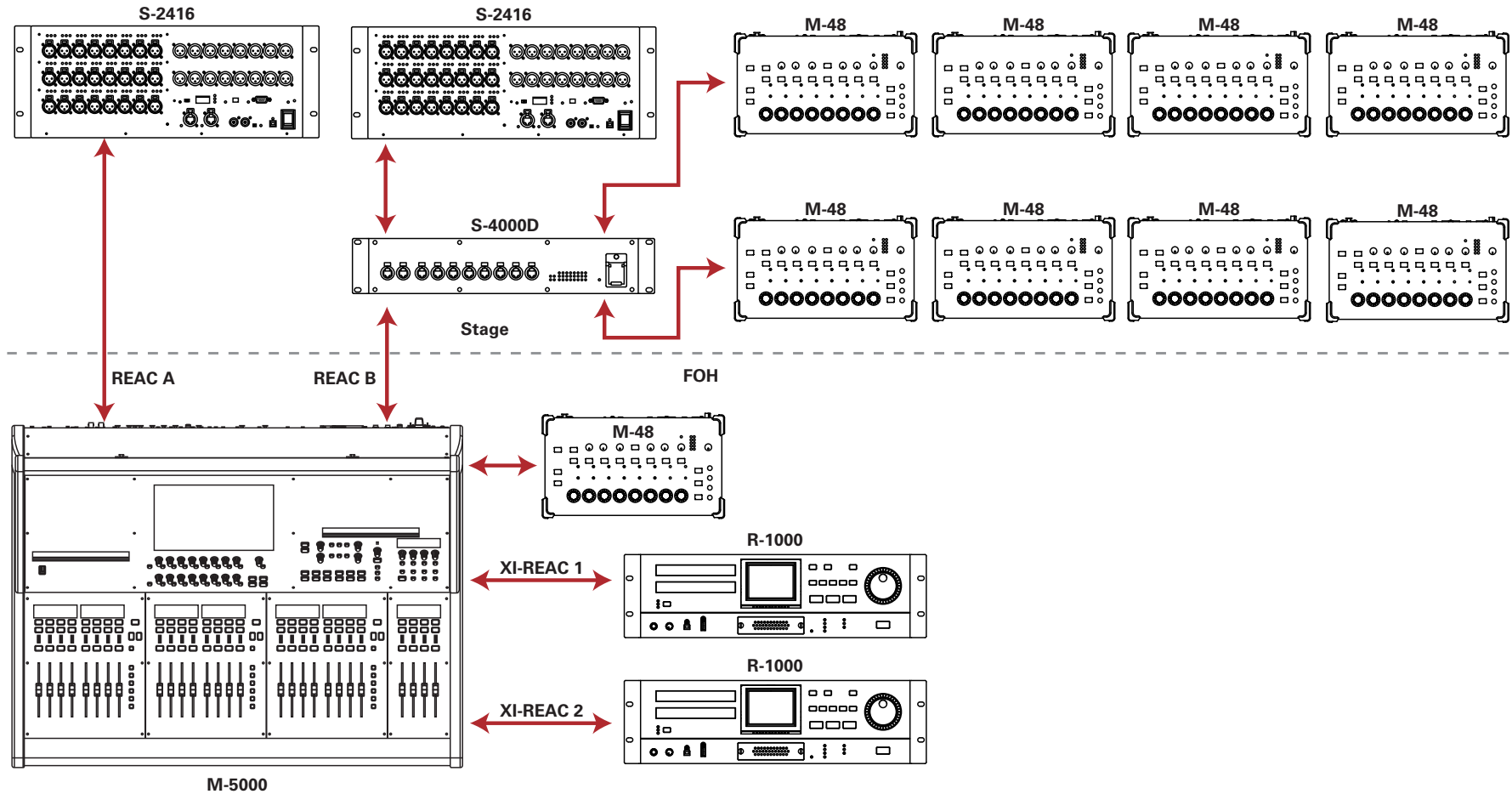

M5000-22416PMR

64x48 Digital Mixing with Personal Mixing and Multi-Channel Playback/Virtual Rehearsal/Recording

This complete system is ideal for an end user interested in harnessing all the power of the REAC network, including 64x48 physical I/O, personal mixing for 8+ engineers monitor, and virtual rehearsal/playback + multi-track recording. The system consists of the configurable M-5000 OHRCA console, two S-2416 Digital Snake heads, two R-1000 Multi-track Recorder/Players, nine M-48 Personal Mixers, an S-4000D Splitter/Distributor and an XI-REAC Expansion Card.

Package includes:

- M-5000 Live Mixing Console
- 2 x S-2416 Digital Snakes
- 2 x R-1000 Multi-Channel Recorder/Player
- 9 x M-48 Personal Mixers
- S-4000D Splitter and Distributor
- XI-REAC Expansion Card

Main Features:

- 128 definable audio paths at 96kHz
- 64 x 48 digital I/O and transport
- Remotely placed and controlled I/O across two snake heads of 24x16
- Personal mixing for 8 plus 1 Engineer's Monitor
- Hardware-based virtual rehearsal/playback and recording of up to 48 channels at 96kHz
- Powerful integrated control from M-5000 surface as well as iPad and/or PC/Mac

System: M5000-22416PMR

Roland
Professional A/V

5100 S. Eastern Avenue
Los Angeles, CA 90040-2938
Phone: (800) 380-2580
www.rolandsystemsgroup.com